

# 2500INT

# Integrating Sphere

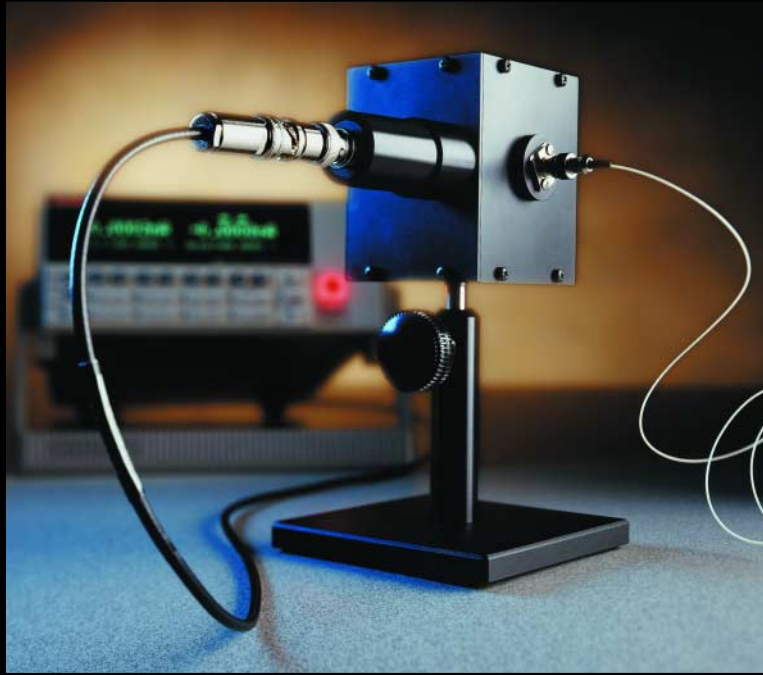

- Choose from silicon, germanium, or cooled indium gallium arsenide detectors
- Spectralon® sphere interior ensures high reflectivity
- Part of Keithley's high throughput system for production testing of laser diodes and LEDs

## Ordering Information

**2500INT-2-Si**  
Integrating Sphere with  
Silicon Detector

**2500INT-2-Ge**  
Integrating Sphere with  
Germanium Detector

**2500INT-2-IGAC**  
Integrating Sphere with  
Cooled Indium Gallium  
Arsenide Detector

This product is available with an  
Extended Warranty.

### Accessories Supplied

Quick Start Guide, Calibration  
Chart for each sphere, TEC  
Controller (included with  
2500INT-2-IGAC)

The Model 2500INT Integrating Sphere is the latest addition to Keithley's growing line of solutions for LIV (light-current-voltage) testing. When connected via a low-noise triax cable to the Model 2500 Dual Photodiode Meter included in Keithley's LIV Test System, the integrating sphere allows the system to make direct measurements of optical power, with results expressed in watts. The integrating sphere simplifies production testing of laser diodes (LDs), light emitting diodes (LEDs), and other optical components by eliminating common optical power measurement problems related to detector alignment, beam profile, polarization, and back reflection.

### Choice of Three Detector Types

The Model 2500INT is available with a silicon (2500INT-2-Si), germanium (2500INT-2-Ge), or cooled indium gallium arsenide (InGaAs) detector (2500INT-2-IGAC), each calibrated with the sphere. Spheres equipped with cooled indium gallium arsenide detectors include a controller to regulate the detector's temperature.

### Unaffected by DUT Beam Profile

Laser diodes can produce non-gaussian beam profiles, which can lead to inaccurate optical power measurements due to underfill or overfill of the detector. While a number of methods are available to correct for underfill and overfill, these methods can add to the overall inaccuracy of the measurement.

In contrast, an integrating sphere is inherently insensitive to beam profiles. The interior of the Model 2500INT integrating sphere has a highly reflective Spectralon surface, which scatters, reflects, and diffuses the source beam produced by the device under test (DUT). This spreads the light from the DUT uniformly over the interior surface of the sphere with minimal absorption loss. A detector can be placed on the interior surface of the sphere, then the sphere/detector combination can be calibrated. The amount of optical radiation striking the detector is the same as any other point on the sphere interior due to the multiple diffuse reflections within the sphere. Therefore, the calibration and resulting measurement accuracy are independent of beam profile.

The Model 2500INT's Spectralon surface offers a variety of other advantages. It is a nearly perfect diffuse reflector, exhibiting Lambertian reflectance properties, so it reflects equally in all directions, regardless of viewing angle. This eliminates the inaccuracies associated with less diffuse materials by distributing the optical radiation more evenly over the interior of the sphere. In addition, a Spectralon surface offers high reflectance for wavelengths from 250-2500nm, which makes it ideal for laser diode measurement applications. It is also chemically inert, which helps ensure stable measurements in harsh environments.

### Eases Beam Alignment

If an integrating sphere is not used in laser diode testing, the entire beam from the laser must shine directly onto the detector in order to measure optical power accurately. However, it is difficult to align a laser and detector with the high degree of precision required, particularly when the laser is operating outside of the visible spectrum. With the use of an integrating sphere, beam alignment is trivial because any light that enters the sphere will be spread evenly across its interior surface. Simply stated, it is easier to direct a laser into a 1/2-inch port than it is to direct a laser onto a 5mm detector. The sphere is insensitive to input beam alignment up to 40° off normal or divergences up to 40° half-angle.

## APPLICATIONS

### Production testing of:

- Laser diode modules
- Chip on submount laser diodes
- Laser diode bars
- LEDs
- Passive optical components

1.888.KEITHLEY (U.S. only)

[www.keithley.com](http://www.keithley.com)

**KEITHLEY**

A GREATER MEASURE OF CONFIDENCE

Enables direct optical power measurement in watts with the Model 2500

OPTOELECTRONIC TEST SOLUTIONS

# 2500INT

# Integrating Sphere

Enables direct optical power measurement in watts with the Model 2500

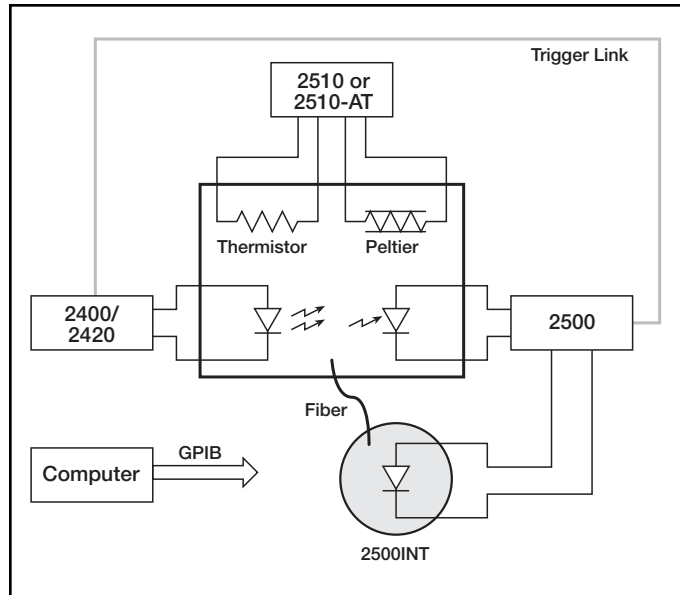

The Model 2500INT allows the LIV Test System to measure optical inputs directly and to display power measurements in watts. Other instruments in the LIV Test System include the Model 2500 Dual Photodiode Meter, the Model 2510 TEC SourceMeter, and either the Model 2400 or 2420 SourceMeter. Each integrating sphere is characterized at the factory and provided with a calibration constant for every 25 nanometers in the detector's range. Prior to testing, the user simply enters the constant in the Model 2500 Dual Photodiode Meter to ensure accurate measurements of optical power for that wavelength.

## Minimizes Polarization Concerns

The randomizing effects of multiple reflections within Keithley's integrating sphere minimize beam polarization problems that can affect optical measurement accuracy when measuring polarized sources. Beam polarization is of particular concern for manufacturers of distributed feedback lasers (DFBs) and Vertical Cavity Surface Emitting Lasers (VCSELs).

## Eliminates Back Reflection

The stability of a laser diode is significantly affected by back reflections from objects in the optical path. The geometric nature of the integrating sphere and the diffusing properties of the sphere's reflective material help prevent back reflection and ensure greater device stability during testing.

## Attenuates High Power Laser Diode Outputs

Detectors have specified maximum power capability, which is typically just a few milliwatts. By spreading the output power evenly over its interior surface, an integrating sphere automatically attenuates the power from the source; therefore, the power level at any point on the sphere surface is far less than that of a beam that falls directly on the detector. The Model 2500INT sphere is particularly useful for testing high-power laser diodes because it provides calibrated attenuation of the laser diode output, which prevents damage to the detector due to the high density of the output or other problems associated with saturation of the detector.

## Designed Specifically for Laser Diode Testing

The design of the Model 2500INT Integrating Sphere is optimized for measuring the optical power of laser diodes. Each sphere is two inches in diameter with a 1/2-inch input port suitable for fiber or direct light (as in chip on sub-mount applications). The port and detector are positioned so there is no need to use a baffle to prevent the input from shining directly onto the detector.

|                                    | SILICON DETECTOR   | GERMANIUM DETECTOR   | COOLED InGaAs DETECTOR  |
|------------------------------------|--|--|---|
| Wavelength Range                   | 190–1100 nm  | 800–1800 nm  | 900–1670 nm   |
| Peak Wavelength ( $\lambda_p$ )    | 960 nm   | 1550 nm  | 1550 nm   |
| Sensitivity at Peak Wavelength     | Excellent at 960 nm  | Good at 1550 nm  | Excellent at 1550 nm  |
| Sensitivity at Certain Wavelengths |  |  |   |
| Visible                            | ***  | N/A  | N/A   |
| 980nm                              | ***  | **   | **  |
| 1310nm                             | N/A  | **   | ***   |
| 1550nm                             | N/A  | **   | ***   |
| >1550nm                            | N/A  | **   | ***   |
| Speed                              | ***  | *  | **  |
| Calibration Accuracy/Stability     | Spectral response changes rapidly with temperature at wavelengths >1000nm. | Spectral response changes rapidly with temperature and $\lambda$ above $\lambda_p$ . | Extremely stable (Spectral response is stable because $\lambda$ calibration is fixed at constant operating temperatures, i.e., $-10^\circ\text{C}$ .) |
| Cost                               | \$   | \$\$   | \$\$\$  |

\* = Good \*\* = Better \*\*\* = Best N/A = not applicable

## Detector Selection Criteria

When choosing the most appropriate detector for a specific application, consider the following selection criteria:

- Wavelengths of maximum interest
- Sensitivity at wavelength of interest
- Speed
- Cost
- Calibration accuracy/stability

1.888.KEITHLEY (U.S. only)

[www.keithley.com](http://www.keithley.com)

**KEITHLEY**

A GREATER MEASURE OF CONFIDENCE

OPTOELECTRONIC TEST SOLUTIONS

# 2500INT

# Integrating Sphere

## SPECIFICATIONS

### TYPICAL REFLECTANCE DATA FOR SPECTRALON MATERIAL

| WAVELENGTH (nm) | SPECTRALON |
|-----------------|------------|
| 500             | .991       |
| 600             | .992       |
| 700             | .992       |
| 800             | .991       |
| 900             | .992       |
| 1000            | .993       |
| 1100            | .992       |
| 1200            | .992       |
| 1300            | .992       |
| 1400            | .991       |
| 1500            | .990       |
| 1600            | .989       |
| 1700            | .986       |
| 1800            | .987       |

### ACCESSORIES AVAILABLE

(Appropriate cables and connectors are required to operate the Model 2500INT Integrating Sphere and must be ordered separately. They are not included with the instrument.)

|                |   |
|----------------|---|
| 7078-TRX-1     | Low-Noise Triax Cable, 0.3m (1 ft)        |
| 7078-TRX-3     | Low-Noise Triax Cable, 0.9m (3 ft)        |
| 7078-TRX-5     | Low-Noise Triax Cable, 1.5m (5 ft)        |
| 7078-TRX-10    | Low-Noise Triax Cable, 3.0m (10 ft)       |
| 7078-TRX-12    | Low-Noise Triax Cable, 3.5m (12 ft)       |
| 7078-TRX-20    | Low-Noise Triax Cable, 6.0m (20 ft)       |
| 2500INT-FC/APC | FC/APC Connector for 2500INT              |
| 2500INT-FC/PC  | FC/PC Connector for 2500INT               |
| 2500INT-SMA    | SMA Connector for 2500INT                 |
| 6172           | 2-Slot Male to 3-Lug Female Triax Adapter |

### PHYSICAL, THERMO-OPTICAL, AND ELECTRONIC PROPERTIES OF SPECTRALON MATERIAL

| PROPERTY                        | ASTM TEST | VALUE   |
|---------------------------------|-----------|---|
| Density                         | N/A       | 1.25–1.5g/cm <sup>3</sup>   |
| Water Permeability              | D-570     | <0.001% (hydrophobic)   |
| Hardness                        | D-785     | 20–30 Shore D   |
| Thermal Stability               | N/A       | Decomposes at >400°C  |
| Coefficient of Linear Expansion | D-696     | 5.5–6.5 × 10 <sup>-5</sup> in/in -°F; 10 <sup>-4</sup> °C <sup>-1</sup>           |
| Vacuum Stability                | N/A       | No outgassing except for entrained air  |
| Flammability                    | N/A       | Non-flammable (UL rating V-0)<br>Incompatible with non-polar solvents and greases |
| Yield Stress                    | D-638     | 208psi  |
| Ultimate Stress                 | D-638     | 891psi  |
| Young's Modulus                 | N/A       | 35774psi  |
| Elongation in 2 in.             | D-638     | 42.8%   |
| Elongation at Failure           | E-132     | 91.3%   |
| Poisson's Ratio                 | D-621     | 0.296   |
| Deformation under Load          | D-621     | 13.3% @ 250 lbs.<br>22.6% @ 500 lbs.  |
| Absorbance (ax)                 | N/A       | 0.07  |
| Emittance (e)                   | N/A       | 0.88  |
| Volume Resistivity              | N/A       | >10 <sup>18</sup> Ω/cm  |
| Dielectric Strength             | D-149     | 18V/μm  |
| Refractive Index                | D-542     | 1.35  |
| Flammability Rating             | UL-94     | V-0   |

### PHOTODIODE SPECIFICATIONS

|                                  | SILICON       | GERMANIUM        | COOLED INDIUM GALLIUM ARSENIDE |
|----------------------------------|---------------|------------------|--------------------------------|
| Wavelength Range                 | 190–1100nm    | 800–1800nm       | 900–1670nm                     |
| Peak Sensitivity Wavelength      | 960nm         | 1550nm           | 1550nm                         |
| Operating Temperature            | -20° to +60°C | -55° to +60°C    | -40° to +70°C                  |
| Storage Temperature              | -55° to +80°C | -55° to +80°C    | -55° to +85°C                  |
| Active Area                      | 2.4mm × 2.4mm | 5.0mm (diameter) | 3.0mm (diameter)               |
| Measurement Temperature          | —             | —                | -10°C                          |
| Thermistor Allowable Dissipation | —             | —                | 0.2mW                          |
| Peltier Element                  | —             | —                | 1.5A                           |
| Allowable Current                | —             | —                | 1.0A                           |

1.888.KEITHLEY (U.S. only)

[www.keithley.com](http://www.keithley.com)

**KEITHLEY**

A GREATER MEASURE OF CONFIDENCE